

SOUTH AFRICA  
LITHIUM  
BATTERIES

LBSA 51.2V 235AH LIFEPO4 BATTERY PACK USER MANUAL

LBSA 48V(51.2V) 235AH SMART BATTERY

# LIFEPO4 BATTERY PACK USER MANUAL

**SOLARFORCE**  
**ENERGY**

Please read this manual carefully before operating  
and retain it for future reference.

This manual introduces LBSA Smart Battery by Lithium Batteries SA. Please read this manual before installation of the battery module and follow the instruction carefully during the assembly. Any confusion, please contact Lithium Batteries SA for advice and clarification.

## CONTENT

1. Safety Precautions.....	
1.1 Precautions.....	
1.2 Warning.....	
2. Introduction.....	
2.1 Features.....	
2.2 Specifications.....	
2.3 Interfaces.....	
2.4 Cell Features.....	
2.4.1 Specifications.....	
2.5 Battery Management System.....	
2.5.1 BMS Functions.....	
2.5.2 Compatible Inverters.....	
3. Installation.....	

### 1. Safety Precautions

This section describes the safety information that must be observed when working with battery packs. To prevent any damages, or personal injury, and to ensure the performance of the battery packs, please read this section carefully and observe the safety precautions at all times.

#### 1.1 Precautions

- It is very important and necessary to read the user manual carefully before installing or using the product. Failure to do so or to follow any of the instructions or warnings in this document can result in electrical shock, serious injury or death, and could damage the battery, or potentially rendering it inoperable.

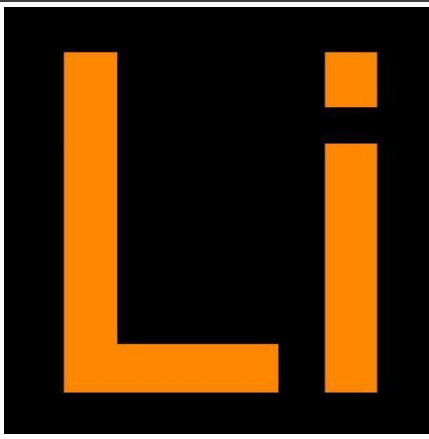

# SOUTH AFRICA LITHIUM BATTERIES

LBSA 51.2V 235AH LIFEPO4 BATTERY PACK USER MANUAL

- If the battery pack is stored for long time, it is required to charge them every six months, and the SOC should be no less than 90%.
- Please recharged the battery pack within 12 hours, after fully discharged.
- All the battery pack terminals must be disconnected before any maintenance.
- Do not use cleaning solvents to clean the battery pack.
- Do not expose the battery pack to flammable or harsh chemicals, or corrosive gases or liquids.
- Do not paint any part of the battery pack, including any internal or external components.
- Do not expose the battery pack to direct sunlight for extended periods of time.
- Do not connect the battery pack with PV solar wiring directly.
- Do not insert any foreign object into any part of the battery pack.

## 1.2 Warning

- Do not touch the battery pack with wet hands.
- Do not crush, drop or puncture the battery pack.
- Always dispose of the battery pack according to local safety regulations.
- Store and recharge the battery pack in a manner in accordance with this user manual.
- Ensure reliable grounding.

- Do not reverse the polarity when installing.
- Do not short circuit the terminals, remove all jewellery items that could cause a short circuit before installation and handling.
- Disconnect battery from power or loads, and then power off battery before installation and maintenance.
- The battery packs should be not stacked more than specified numbers.
- Continued operation of a damaged battery pack can result in a fire.



LBSA lithium iron phosphate battery pack is a household renewable energy storage solution developed and produced by Lithium Batteries SA. After fully installation, it is a low-voltage DC battery system with an operating voltage of 51.2V, and works with a low voltage inverter to realize the goal of energy storage for home application.

The battery pack supports parallel connection to expand capacity, which can meet various capacity requirements. It has a built-in battery management system (BMS), which can manage and monitor the pack and cell information including voltage, current and temperature. What's more, BMS can balance cells charging and discharging to extend cycle life.

## 2.1 Features

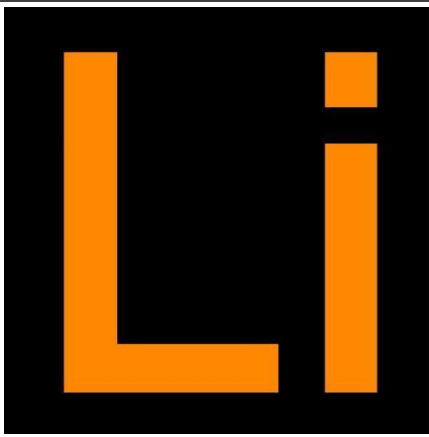

# SOUTH AFRICA LITHIUM BATTERIES

## LBSA 51.2V 235AH LIFEPO4 BATTERY PACK USER MANUAL

- Battery cell is 3.2V 235Ah aluminium case prismatic cell.
- Battery cell is made from lithium iron phosphate (LiFePO<sub>4</sub>) with safety performance and longer cycle life.
- BMS has over-discharge, over-charge, over-current, high and low temperature warning and protection functions.
- BMS monitors charge and discharge state, and balances current and voltage of each cell.
- Flexible configuration, max. 16 packs can be connected in parallel for expanding capacity and power with 8 DIP switches.
- Working temperature range is from -20°C~50°C (Charging 0°C~50°C; discharging -20°C~50°C) with excellent discharge performance and cycle life.

### 2.2 Specifications

Basic Parameters	
Nominal Voltage (V)	51.2V V
Nominal Capacity (Ah)	235Ah
Nominal Power (Wh)	12 kWh
Dimension (mm)	730*225*280mm
Weight (Kg)	>80KG
Discharge Cut-off Voltage (V)	44V

Charge Voltage (Bulk + Absorption) (V)	56V
Max Discharge Current (A)	200A
Recommended Charge Current	100A
Communication Interface	CAN
Configuration	16S
Working Temperature	0~50°C (Charge)
	-20~50°C (Discharge)
	-20~55°C (Storage)
Cell chemistry	Lithium iron phosphate (LiFePO4)
Cycle life	≥80% capacity state after 4800 cycles at 0.5C, 25°C, 100% DOD
IP level	IP 20

### 2.3 Interfaces

#### RESET

Reset button: to start the battery pack, press the button down to turn on battery pack.

#### RS485 (For parallel communication only)

RS485 communication interface: RJ45 port, follow RS485 protocol. For transmitting battery pack information between paralleled packs. Use a standard RJ45 cable. This unit is compatible with LBSA 5.1kWh & 6.1kWh SMART batteries.

Pin	Definition
PIN 1, 8	RS485-B
PIN 2, 7	RS485-A
PIN 3, 6	Ground
PIN 4,5	NC (Bridge weld)

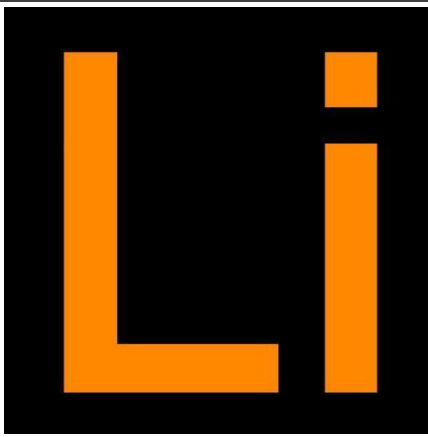

# SOUTH AFRICA LITHIUM BATTERIES

LBSA 51.2V 235AH LIFEPO4 BATTERY PACK USER MANUAL

## CAN

CAN communication interface: follow CAN BUS protocol, for output pack information to inverter.

### RJ-45 CAN BUS PINOUT

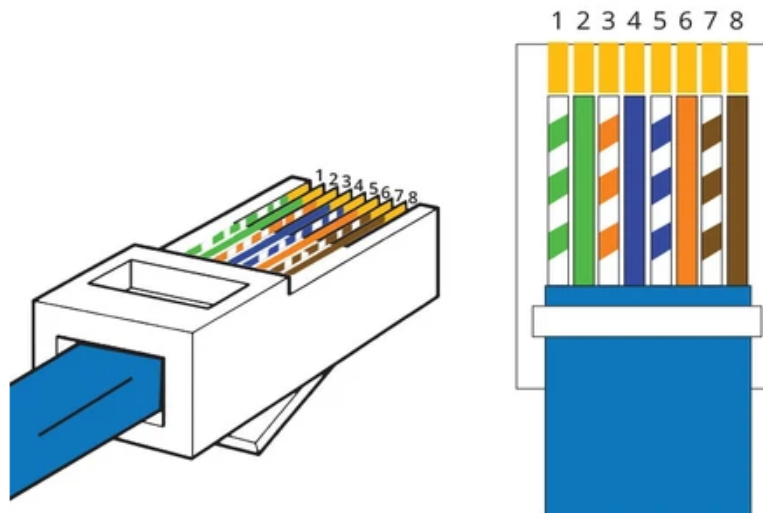

Pin 3:	Ground
Pin 4:	CAN-H
Pin 5:	CAN-L

## ADDRESS

ADS Switch: To setup battery address, and to communicate between battery and Inverter.

NOTE: There are 8-bit DIP switches, keep the switch on down side means 'OFF', turn up the switch to top side means 'ON'.

CAN communication DIP address should setup as the following table.

CAN Communication									
Master Packs (#1, #2, #3, #4 set OFF) #5, #6, #7, #8 set as follows					Slave Packs (#5, #6, #7, #8 set OFF) #1, #2, #3, #4 set as follows				
	8	7	6	5		4	3	2	1
One pack	OFF	OFF	OFF	OFF					
2 packs in parallel	OFF	OFF	OFF	ON	1 <sup>st</sup> slave pack	OFF	OFF	OFF	ON
3 packs in parallel	OFF	OFF	ON	OFF	2 <sup>nd</sup> slave pack	OFF	OFF	ON	OFF
4 packs in parallel	OFF	OFF	ON	ON	3 <sup>rd</sup> slave pack	OFF	OFF	ON	ON
5 packs in parallel	OFF	ON	OFF	OFF	4 <sup>th</sup> slave pack	OFF	ON	OFF	OFF
6 packs in parallel	OFF	ON	OFF	ON	5 <sup>th</sup> slave pack	OFF	ON	OFF	ON
7 packs in parallel	OFF	ON	ON	OFF	6 <sup>th</sup> slave pack	OFF	ON	ON	OFF
8 packs in parallel	OFF	ON	ON	ON	7 <sup>th</sup> slave pack	OFF	ON	ON	ON
9 packs in parallel	ON	OFF	OFF	OFF	8 <sup>th</sup> slave pack	ON	OFF	OFF	OFF
10 packs in parallel	ON	OFF	OFF	ON	9 <sup>th</sup> slave pack	ON	OFF	OFF	ON
11 packs in parallel	ON	OFF	ON	OFF	10 <sup>th</sup> slave pack	ON	OFF	ON	OFF
12 packs in parallel	ON	OFF	ON	ON	11 <sup>th</sup> slave pack	ON	OFF	ON	ON
13 packs in parallel	ON	ON	OFF	OFF	12 <sup>th</sup> slave pack	ON	ON	OFF	OFF
14 packs in parallel	ON	ON	OFF	ON	13 <sup>th</sup> slave pack	ON	ON	OFF	ON



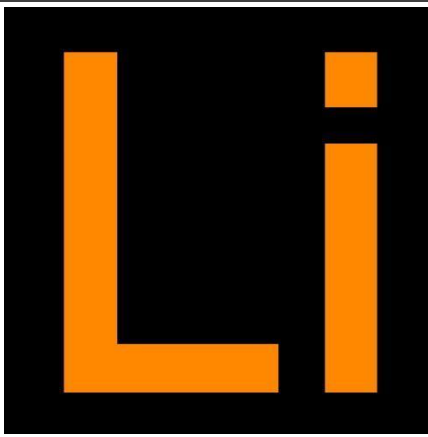

# SOUTH AFRICA LITHIUM BATTERIES

LBSA 51.2V 235AH LIFEPO4 BATTERY PACK USER MANUAL

15 packs in parallel	ON	ON	ON	OFF	14 <sup>th</sup> slave pack	ON	ON	ON	OFF
16 packs in parallel	ON	ON	ON	ON	15 <sup>th</sup> slave pack	ON	ON	ON	ON

## ALARM

ALARM light: red LED flash to show the battery alarm status.

And red light permanently to show the battery in protection status of abnormal temperature, over-current, or short-circuit.

## RUN

Working light: green LED to show the battery working status.

Details as follows,

Battery status	Operating Mode	RUN	ALM	LED Light				Remark
		●	●	●	●	●	●	
Power off	Standby	OFF	OFF	OFF	OFF	OFF	OFF	OFF
Standby	Normal	Solid Green	OFF	According to battery SOC status				Standby mode
Charge Mode	Normal	Solid Green	OFF	According to battery SOC status				
	Over current warnings	Solid Green	Blink type 2					
	Over voltage protection	Blink type1	OFF	OFF	OFF	OFF	OFF	

	Temperature , over current protection	Blink type1	OFF	OFF	OFF	OFF	OFF	
Discharge Mode	Normal	Blink type 3	OFF	According to battery SOC status				
	Warning	Blink type 3	Blink type 3					
	Over current, temperature , short-circuit protection	OFF	Solid Red	OFF	OFF	OFF	OFF	Termination of discharge
	Under voltage protection	OFF	OFF	OFF	OFF	OFF	OFF	Termination of discharge

**CAPACITY**

SOC light: 4 green LED lights to show the capacity status of battery pack. Each LED represents 25% the capacity.

Status	Charge				Discharge			
Capacity indicator	● L4	● L3	● L2	● L1	● L4	● L3	● L2	● L1
0-25%	OFF	OFF	OFF	Blink	OFF	OFF	OFF	Solid Green
25%-50%	OFF	OFF	Blink	Solid Green	OFF	OFF	Solid Green	Solid Green
50%-75%	OFF	Blink	Solid Green	Solid Green	OFF	Solid Green	Solid Green	Solid Green
>75%	Blink	Solid Green	Solid Green	Solid Green	Solid Green	Solid Green	Solid Green	Solid Green
Operating indicator	Solid Green				Blink			

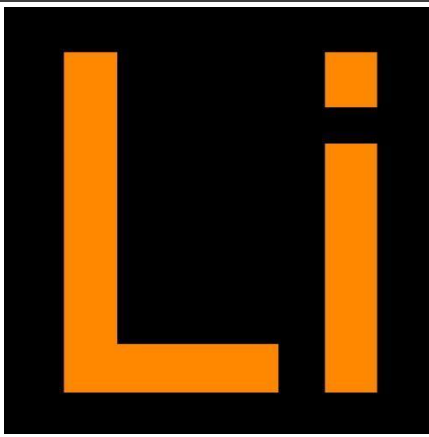

# SOUTH AFRICA LITHIUM BATTERIES

LBSA 51.2V 235AH LIFEP04 BATTERY PACK USER MANUAL

P+/P-

Power terminals: one pairs of power terminals to go directly to a single inverter if one pack is used. If more than one pack is used the batteries must be connected to a busbar with equal length cable to ensure there is equal discharge and charge between the batteries

Power cable uses 10.0mm lug to connect to the battery terminals.

## 2.4 Cell Features

### 2.4.1 Specifications

CALB 3.2V 235Ah lithium iron phosphate (LiFePO<sub>4</sub>) aluminium case prismatic rechargeable battery cell.

	Nominal Voltage	3.2V
	Nominal Capacity	235Ah
	Weight	≤4.3Kg
	Self-discharge Rate	≤3.5% per month
	Initial Internal Resistance (1KHz)	≤0.35mΩ

Refer to the cell specification for more detailed information.

High quality Grade A cells are inside the battery box

Judging by the current testing report below, if the battery pack charging and discharging at 0.2C, the battery pack could reach a cycle life of 6000 times or more at the remaining capacity of 80% capacity state at 25°C room temperature, 100%DOD.

- The real capacity of each single cell is 235Ah.

### 2.5 Advanced Battery Management System (BMS) inside

The BMS is applied to monitor current, voltage, temperature, protection against over-charge, over-discharge, over-current, over-temperature, under-temperature and short circuit. The BMS provides cell balancing and current limitation during the charging process to ensure a reliable safety and performance.

The BMS will automatically adjust the Available capacity after every full charge of 56v when discharged.

This capacity will be influenced by the Temperature as the cells generally have less capacity available under very cold temperatures.

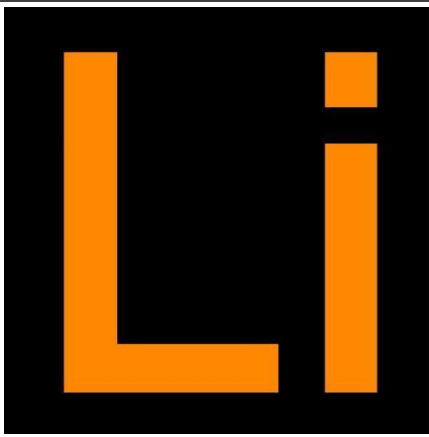

# SOUTH AFRICA LITHIUM BATTERIES

LBSA 51.2V 235AH LIFEPO4 BATTERY PACK USER MANUAL

## 2.5.1 BMS Functions

- Over charge protection
- Over discharge protection
- Overcurrent protection
- Cell balancing
- Temperature protection
- CAN communication to inverters and RS485 communication between battery packs

2.5.2 Compatible Inverters (with regards to CANbus Communication), all other inverters should have the charge and discharge cut-off set with accordance to section 2.2 on the Manual

- Victron
- Growatt(Straight RJ45 cable to be used from the battery CAN port and the inverter CAN port)
- Goodwe(Straight RJ45 cable to be used from the battery CAN port and the inverter CAN port)
- Sunsynk(Straight RJ45 cable to be used from the battery CAN port and the inverter CAN port)
- Deye(Straight RJ45 cable to be used from the battery CAN port and the inverter CAN port)

- LuxPower(For Luxpower models before September 2022 refer to the Luxpower to LBSA document to be obtained from your supplier. For newer models use straight pin to in connection. NB: BATTERY CAN PROTOCOL NEEDS TO BE SET TO LUXPOWER USING THE BATTERY MONITOR CABLE SUPPLIED BY LBSA)

### 3. Installation

When connecting the batteries in Parallel the batteries should be connected to a central Busbar and from the busbar be distributed to the inverters with equal cable lengths.

This unit is compatible with LBSA 5.1kWh & 6.1kWh SMART batteries.

M10 rawl bolts to be used to mount the wall bracket to a wall (please ensure that the surface/structure/wall is capable of carrying the unit weight)

This document is subject to change without notice.